

UNION FOR DEMOCRATIC COMMUNICATIONS

CIRCUITS OF STRUGGLE

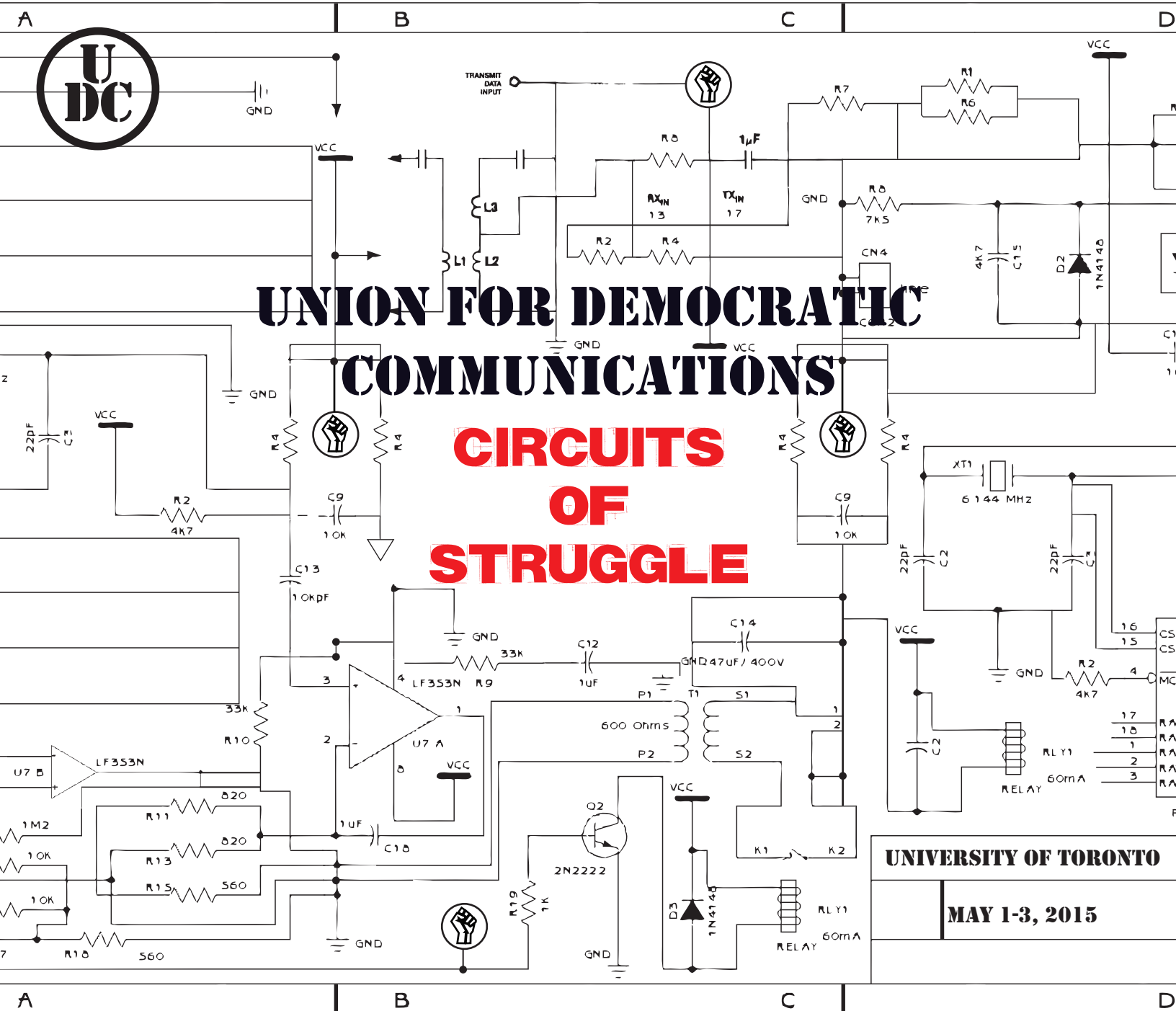

UNIVERSITY OF TORONTO

MAY 1-3, 2015

Union for Democratic Communications

University of Toronto

May 1 - 3, 2015

Welcome from the local organizers

We are pleased to welcome everyone to the 2015 *Union for Democratic Communications Conference: Circuits of Struggle*. We would like to acknowledge that the land on which our conference takes place is the territory of the Huron-Wendat and Petun First Nations, the Seneca, and most recently, the Mississaugas of the Credit River. The territory was the subject of the Dish With One Spoon Wampum Belt Covenant, an agreement between the Iroquois Confederacy and the Ojibwe and allied nations to peaceably share and care for the resources around the Great Lakes. Today, the meeting place of Toronto is still the home to many indigenous people from across Turtle Island. We are grateful to have the opportunity to work in the community and on this territory. Also, our conference falls on May 1st—better known as International Workers’ Day. Thus, we honour the individuals and groups struggling against exploitation all over the world.

This marks the first UDC conference held outside of the United States since 2007. Hosted at the University of Toronto’s historic downtown campus, this year’s conference brings together distinguished and emerging scholars in the field of communications, as well as activists and academics dedicated to the establishment of oppositional, independent, and democratic media systems. We are thrilled to present a conference program with a strong activist track, featuring scholar-activists, media makers, labour organizers, and community members from many different countries. In addition, we endeavoured to ensure that

our program is inclusive and representative of the diversity that constitutes the UDC membership.

We have a busy conference planned for you. We hope you enjoy the keynote lectures, workshops, UDC membership meetings and many presentations. The next three days promise to be both thought-provoking and fun. Best wishes for a great conference!

Your local organizing committee,

Dr. Brett Caraway, University of Toronto Mississauga

Dr. Nicole Cohen, University of Toronto Mississauga

Gretchen King, McGill University

Welcome from the UDC

Welcome to the 2015 Union for Democratic Communications conference!

One of the chief goals the UDC Steering Committee has been working towards over the last several years has been the desire to build on the rigor and the inclusiveness of the organization. Many of the conversations we've had in recent years have emphasized the calling of activism wed with academic rigor. Rather than seeing them as separate tracks, we've sought to treat them as parts of a whole, inherently and necessarily intertwined. This conference represents the fruits of that work, building on the lessons and successes of past conferences.

We are fortunate to have worked with the excellent local organizing committee of Nicole Cohen, Brett Caraway, and Gretchen King, who have gone above and beyond to not only craft an excellent program but to also help find ways to support and include a broad range of participants. We're all quite proud of the program and the theme they've worked so hard on, which provides a useful lens to examine and address a number of important issues of the day.

As always, it is our hope that both the program and the organization continue to further the community of scholars, the conversations about these important issues, and the continued struggle your work represents. None of this would be possible without your continued engagement, so thank you. And enjoy the conference.

Randy Nichols
Coordinator, UDC Steering Committee

Circuits of Struggle

The Union for Democratic Communications is dedicated to the critical study of ascendant, emergent, oppositional, democratic, and experimental forms of media, their production and distribution, and the development of local, regional and international systems of democratic communication. In this spirit, the organizers of the 2015 conference asked that participants engage with the theme of *circuits of struggle*.

Contemporary communication practices are marked by struggle. On the one hand, we live amid neoliberalism and austerity and the challenges these structures impose on democratic life, including precarity, debt, and enclosure. Capitalism has integrated communicative activity and digital technologies into a logic of accumulation that exploits all forms of the commons: the environment, languages, affects, information, and knowledge. Technological innovation makes possible new forms of surveillance and corporate control over these resources. On the other hand, this integration is incomplete. Individuals, organizations, and collectives are using these same technologies to fight back. Struggles for higher wages, less work, social justice, and a better quality of life are occurring worldwide. Those who struggle against domination are communicating across new channels in innovative and creative ways.

In this context, the 2015 UDC conference is dedicated to engaging in conversations about the nature of contemporary media, communication, and technological struggle, and the possibilities for transforming the contemporary neoliberal order.

Program Highlights

Friday May 1st

12:30 - 2:00pm

Activist Keynote

Peter Bloom and Loreto Bravo: Building Indigenous Circuits of Struggle: Community Media in Oaxaca

Howard Ferguson Hall, 75 St. George Street, free public event

4 - 7pm

Workshop

Building Mini FM Radio Transmitters with Peter Bloom and Loreto Bravo, Bissell first floor

5:30 - 7pm

Book Launch: *Nothing to Lose But Our Fear: Resistance in Dangerous Times* by Fiona Jeffries, Semaphore Demo Room, Roberts main floor

7:30 - 9pm

Keynote Lecture

Astra Taylor: Taking Back Power in the Age of Networks

Bahen Centre, 40 St. George Street, free public event

Saturday May 2nd

9:30 - 10:45am

Dallas Smythe Award and Keynote Lecture

Professor Robert Hackett (Simon Fraser University)

Bahen Centre, 40 St. George Street

12:45 - 1:45pm

Lunch and UDC General Membership Meeting

Howard Ferguson Hall, 75 St. George Street

6:00 - 7:30pm

Saturday Night Plenary and Dinner (doors open at 5:15)

Circuits of Struggle: Resistance, Re-Appropriation and Repurposing in Global Networks of Class Struggle

With Nick Dyer-Witheford, Alison Hearn, Harry Cleaver & Ursula Huws, Burwash Dining Hall, 89 Charles St. W.

Sunday May 3rd

9 - 10:30am

UDC Business Meeting (all welcome)

Howard Ferguson Hall, 75 St. George Street

1:30 - 2:45pm

Closing Plenary and Lunch

Ruptures and Critical Junctures: Moments of Media Activism in Historical and Global Context

With Todd Wolfson, Anita Say Chan, Victor Pickard, Christina Dunbar-Hester and Deepa Kumar

Howard Ferguson Hall, 75 St. George Street

Conference Schedule

Friday May 1st

8 - 9am **Breakfast**

Bissell Building, lobby

9 - 10:30am **Panel Session 1**

Panel 1A	The World Forum of Free Media (WFFM) and the Charter of Free Media
Date	Friday
Time	9 - 10:30am
Room	Bissell 224
Chair	Stéphane Couture
	<ul style="list-style-type: none">• Stéphane Couture (McGill University)• Gretchen King (McGill University)• Sophie Toupin (McGill University)

Panel 1B	Historical Perspectives on Media, Representation, and Struggle
Date	Friday
Time	9 - 10:30am
Room	Bissell 538
Chair	Brian Creech
	<ul style="list-style-type: none">• Lee McGuigan (University of Pennsylvania) Procter & Gamble, Mass Media, and the Making of American Life• Kristen Hoerl (Butler University) Growing Up and Selling Out: Fictional Television Portrayals of the Sixties Counterculture During the Reagan Revolution• Robert MacDougall (Western University) A Fight With an Octopus: Lessons from the Struggle for a People's Telephone 100 Years Ago• Rianne Subijanto (University of Colorado Boulder) Openbare Vergaderingen and the Geography of Resistance

Panel 1C	The Promises and Complexities of Open Data
Date	Friday
Time	9 - 10:30am
Room	Bissell 728
Chair	Karen Smith
	<ul style="list-style-type: none"> • Andrew Clement (University of Toronto) and Jonathan Obar (Michigan State University) Data Privacy Transparency Reporting in Canada: The 'Keeping Internet Users in the Know or in the Dark' Reports • Daniel Paré (University of Ottawa) Enhanced Democracy? Really? Assessing Design-Reality Gaps in Canadian Municipal-level Open Government Platforms • Evan Hamilton (University of Toronto) A Critical Analysis of Open Data Policies in Ontario Municipalities

Panel 1D	Every Step You Take: Surveillance in the Digital Age
Date	Friday
Time	9 - 10:30am
Room	Bissell 507
Chair	Anthony Nadler
	<ul style="list-style-type: none"> • Anthony Nadler (Ursinus College) Captains of Habit Formation: Marketing in the Age of Big Data • Shea Smock (Independent) and Jennifer Proffitt (Florida State University) The Oppression and Potential of Digital Surveillance • Timothy Libert (University of Pennsylvania) The Logic of Connective Surveillance • Jeff Blevins (University of Cincinnati) and Duncan Brown (Ohio University) The Panoptic Missort: The Political Economy of Digital Media Privacy

Panel 1E	Roundtable: Professors, Partners, and Parents: The State of Work-Family Policies in the Academy
Date	Friday
Time	9 - 10:30am
Room	Bissell 310
Chair	Safiya Noble
	<ul style="list-style-type: none"> • Molly Niesen (Eastern Illinois University) • Safiya Noble (UCLA) • Christine Quail (McMaster University) • Michelle Rodino-Colocino (Penn State University)

Panel 1F	May We Have Your Attention, Please? Critical Perspectives on Advertising
Date	Friday
Time	9 - 10:30am
Room	Bissell 225
Chair	Andrea Benoit
	<ul style="list-style-type: none"> • Inger Stole (University of Illinois) Advertising America: Selling Europe on Free Enterprise in the late 1940s • Kyle Asquith (University of Windsor) Resisting Advertising in Schools: The Case of the Canadian Youth News Network • Andrea Benoit (Western University) 'Heart and Soul:' Promoting the M.A.C AIDS Fund in the Contemporary Brandscape • Anne MacLennan (York University) Creating Empathy or Sympathy? The Global Images of Poverty in Charitable Campaign Advertising

10:30 - 10:45

Coffee Break
Bissell Building, lobby

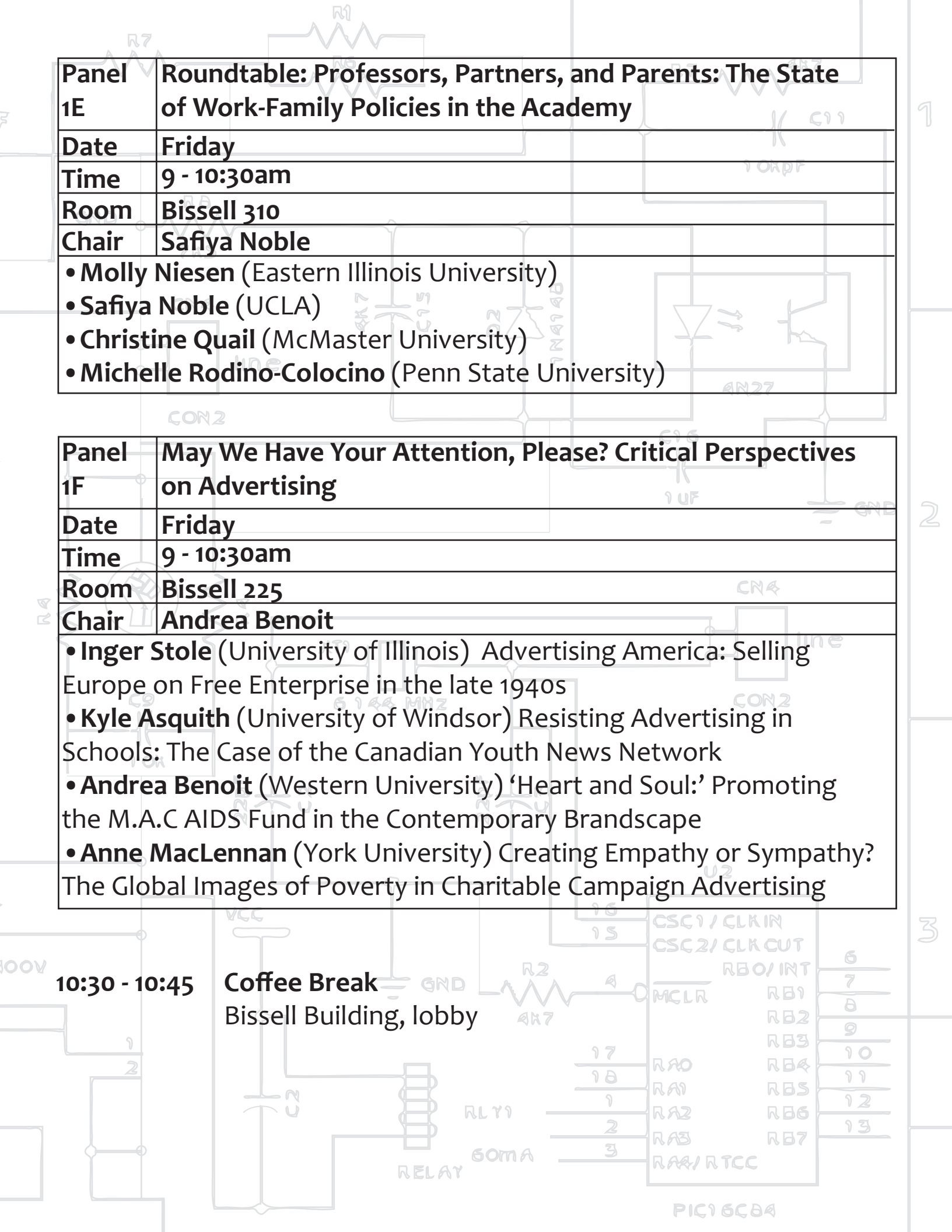

10:45 - 12:15 Panel Session 2

Panel 2A	Posters from Social Movements in Quebec, 1964-2014
Date	Friday
Time	10:45 - 12:15pm
Room	Semaphore Demo Room, Robarts Main Floor
	<ul style="list-style-type: none"> • Jean-Pierre Boyer (CRIP-UQAM) • Jean Desjardins (CRIP-UQAM)

Panel 2B	New Views on History as Theory for Critical Communications Research
Date	Friday
Time	10:45 - 12:15pm
Room	Bissell 728
Chair	James F. Hamilton
	<ul style="list-style-type: none"> • Victor Pickard (University of Pennsylvania) History as a Weapon: Destabilizing the Present for an Alternative Future • Molly Niesen (Eastern Illinois University) Witnessing Change: The Powell Memo, Industry Archives, and the Rise of a Neoliberal Consensus • Brian Creech (Temple University) Seeing Things in Context: Historicizing Technology and Practice • Matthew Crain (CUNY – Queens College) Historical Social Construction as a Defusing Concept • James F. Hamilton (University of Georgia) The Presence of the Past: Radical History as Critical Social Theory in the British New Left

Panel 2C	Circuits of Struggling Interns: Internships, Social Justice, and Resistance
Date	Friday
Time	10:45 - 12:15pm
Room	Bissell 538
Chair	Sandra Smeltzer
	<ul style="list-style-type: none"> • Michelle Rodino-Colocino (Pennsylvania State University) and Stevie Berberick (Pennsylvania State University) “You Kind of Have to Bite the Bullet and do Bitch Work”: How Internships Teach Students to Unthink Exploitation in Public Relations • Jenna Jacobson (University of Toronto) and Leslie Regan Shade (University of Toronto) Short Circuiting the Struggle of Precarious Work • Sandra Smeltzer (Western University) Challenging the Neoliberal Order Through Social Justice-Oriented Communication Internships • William Webb (Wilfrid Laurier University) Ontario Interns Fight Back: Modes of Resistance Against Unpaid Internships in Ontario

Panel 2D	Media Perspectives on War and Violence
Date	Friday
Time	10:45 - 12:15pm
Room	Bissell 310
Chair	Kim Nguyen
	<ul style="list-style-type: none"> • Abbe Depretis (Temple University) Race, Consumption, and the Politics of Looting • Kim Nguyen (University of Waterloo) Post-9/11 Iconic Photography and World War II’s Analogical Aesthetic • Michelle Kearn (Indiana University-Purdue University), Nadia Martinez-Carrillo (Indiana University-Purdue University) and Daniel Tamul (Indiana University-Purdue University) Holy Drones!: Media Framing and the Writing of a Hagiography of American Predator Drones

Panel 2E	Redefining Community Through Advocacy and Alternative Media
Date	Friday
Time	10:45 - 12:15pm
Room	Bissell 507
Chair	Gretchen King
	<ul style="list-style-type: none"> • Maggie Reid (Ryerson University) ICTV-Toronto: Independent, Community led Media in the Making • Gretchen King (McGill University) The Radical Pedagogy of Community Radio and the Case of Radio al-Balad 92.4 FM: Community Radio, News Audiences and Political Change in Jordan • Crystal R. China (University of Georgia) Can Prisoners Speak? Advocacy Media Organization, Form and Practice in The Sentencing Project, 1986-2014

Panel 2F	Social Media and Social Movements
Date	Friday
Time	10:45 - 12:15pm
Room	Bissell 225
Chair	Matthew Flisfeder
	<ul style="list-style-type: none"> • Rhon Teruelle (University of Toronto) Carrément dans le rouge • Jaigris Hodson (Ryerson University) and Omar Grant (Ryerson University) #Ferguson: Twitter on the Front Lines • Matthew Flisfeder (Ryerson University) *Social* Media Does Not Exist: A Critical Reading of Social Media “Revolutions” • Hend Abdalmotagally (Cairo University) An Ethnographic Study of the Re-conceptualization of Opinion Leadership via Twitter amongst Egyptian Revolutionaries in The Post-Jan25 Revolution Era

Panel 2G	Struggles for Food and Justice
Date	Friday
Time	10:45 - 12:15pm
Room	Bissell 224
Chair	Christina Ceisel
<ul style="list-style-type: none"> • Garrett Broad (University of Pennsylvania) Stories of Food and Justice: Competing Visions of Youth Empowerment • Jaclyn Nardone (Western University) From The Kitchen To The Streets: Fast-Food Workers Protest For Labour Rights • Diana Eidson (Auburn University) La Vía Campesina International Peasant’s Movement: Circuits of Struggle for Food Sovereignty 	

12:30 - 2pm

Lunch and Activist Keynote

Howard Ferguson Hall, 75 St. George Street

Peter Bloom and Loreto Bravo

Building Indigenous Circuits of Struggle: Community Media in Oaxaca

This talk focuses on how indigenous communities in Oaxaca are building and rethinking community media in terms of both infrastructure and content in order to preserve indigenous languages, promote and protect human, cultural and socioeconomic rights, and organize resistance to capital’s exploitation and enclosure of life, land, and livelihood.

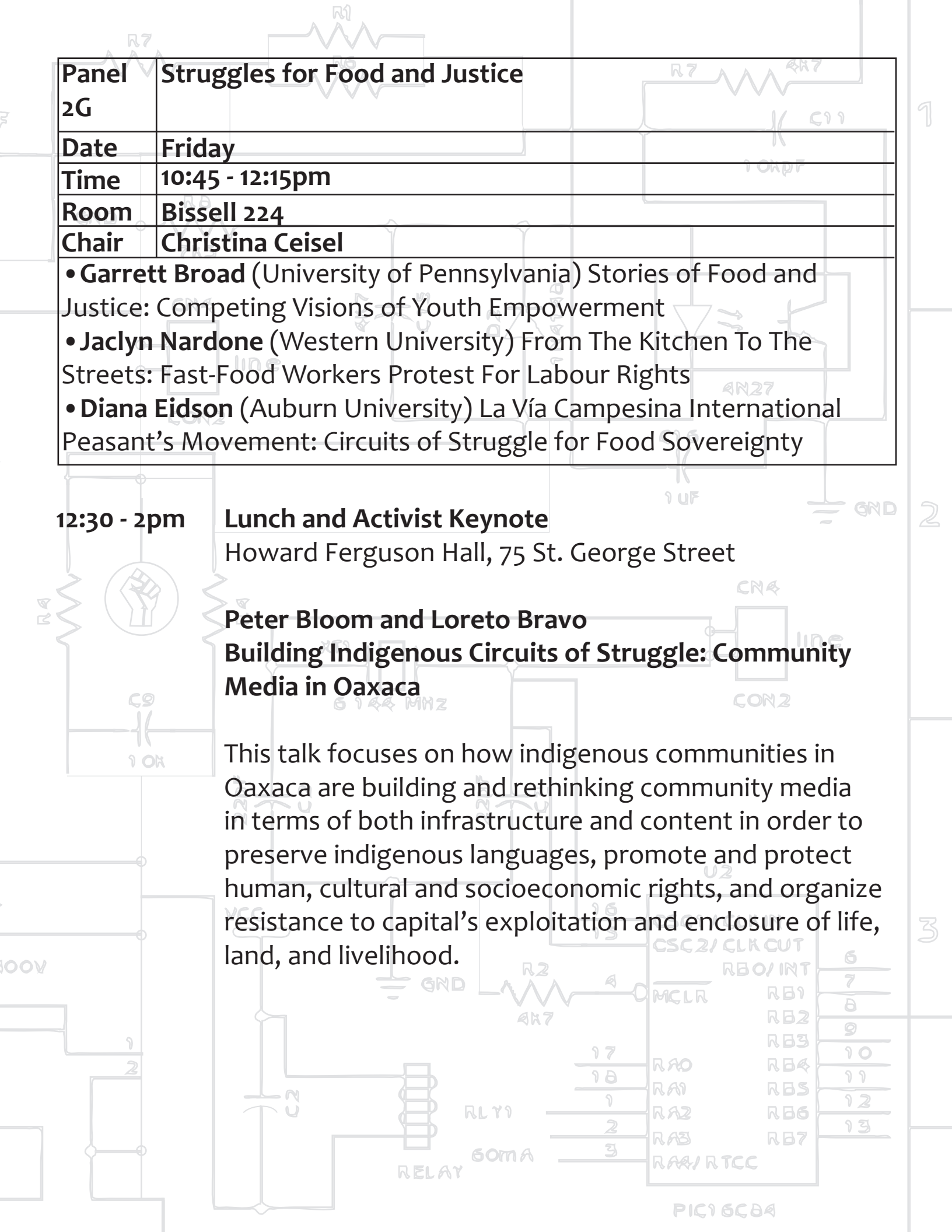

2:15 - 3:45pm Panel Session 3

Panel 3A	Media Education and News 2.0: Solutions for the Digital Generation
Date	Friday
Time	2:15 - 3:45pm
Room	Semaphore Demo Room, Robarts Main Floor
Chair	Rob Williams
	<ul style="list-style-type: none"> • Rob Williams (ACME) Media Education For A Digital Nation (2015) • Julie Frechette (ACME) Media Education For A Digital Nation (2015) • Nolan Higdon (Project Censored) Censored 2015: Inspiring We The People

Panel 3B	Perspectives on Political Economy in the Era of Ubiquitous Media and Markets
Date	Friday
Time	2:15 - 3:45pm
Room	Bissell 507
Chair	Vincent Manzerolle
	<ul style="list-style-type: none"> • Vincent Manzerolle (University of Windsor) Consumption Capacity and the Convergence of Finance and Digital Media: Contributions to a Field Theory of Ubiquitous Media and Markets • Lee McGuigan (University of Pennsylvania) and Graham Murdock (Loughborough University) The Medium is the Marketplace: Producing Consumption in Digital Times

Panel 3C	Activating Bodies In/to Digital Media Networks: Materiality, Narratives and Molotov Cocktails
Date	Friday
Time	2:15 - 3:45pm
Room	Bissell 538
Chair	Mary Elizabeth Luka
	<ul style="list-style-type: none"> • Marusya Bociurkiw (Ryerson University) Molotov Cocktails & Facebook Pages: Feminist Uses of Embodied & Digital Protest in Eastern Europe • Laura Forlano (Illinois Institute of Technology) Hacking the Feminist Body: Media, Materiality and Things • Mary Elizabeth Luka (Ryerson University) Regulatory Bodies: Let's Not Talk TV Anymore • Mél Hogan (Illinois Institute of Technology) Electromagnetic Soup: EMFs, Bodies, and Surveillance

Panel 3D	Second Shifts: Women's Labour and Feminist Activism
Date	Friday
Time	2:15 - 3:45pm
Room	Bissell 225
Chair	Aimee-Marie Dorsten
	<ul style="list-style-type: none"> • Rosemary Clark (University of Pennsylvania) The Dramatic Form of Hashtag Feminism: A Case Study of #WhyIStayed • Natalia Pietrzykowski (University of Toronto) Digital "Women's Work:" Commodification and Capitalist Reproduction on Pinterest • Aimee-Marie Dorsten (Point Park University) Women in Communication: A Challenge to the Imagination

Panel 3E	Protest Beyond the Law: Hacktivism in Class Struggle
Date	Friday
Time	2:15 - 3:45pm
Room	Bissell 728
Chair	Safak Etike
	<ul style="list-style-type: none"> • Safak Etike (Ankara University) Technology as a Practice of Class Struggle: Red Hackers During Gezi Protests • Rianka Singh (McMaster University) On Hacker Manifestos, Collectivity, and Violence • Anne-Sophie Letellier (Université du Québec à Montréal) Aesthetics of Anonymity: A Symbolic Resistance in a Time of Globalized Surveillance • Nazli Bulay Dogan (Koc University) Between a Social Movement and a Revolutionary Promise: The Case of RedHack

Panel 3F	Journalism as a Site of Struggle
Date	Friday
Time	2:15 - 3:45pm
Room	Bissell 310
Chair	Errol Salamon
	<ul style="list-style-type: none"> • Brandale Mills (Howard University), Alisa Valentin (Howard University) and Dionne Clemons (Howard University) The Transition: An Examination of Black Female Journalists' Departure from the Newsroom to the Blogosphere • Syed Irfan Ashraf (Southern Illinois University Carbondale) Journalists Held Hostage: Reporting on Terror from the Tribal Belt of Pakistan • Sean Phelan (Massey University) & Leon Salter (Massey University) When the Journalist Becomes an Advocate: Campbell Brown, Teacher Tenure Reform and Neoliberal Reason • Robin Andersen (Fordham University) Citizenfour and the Challenge to Government Surveillance

Panel 3G	Restructuring Space and Place: Critical Intersections of the Virtual and Physical
Date	Friday
Time	2:15 - 3:45pm
Room	Bissell 224
Chair	Chris Russill
<ul style="list-style-type: none"> • Chris Russill (Carleton University) The Programmable Earth: Google Earth's "Climate Change Tours" and the Geoengineering of Perception and Planet • Gemma Richardson (Humber College) and Dan Rowe (Humber College) Dissent in the Tar Sands: Depictions of Tar Sands Opponents in Local Newspapers in Northern Alberta • Ali Karimi (McGill University) Street Fight: The Politics of Place-Naming in Kabul City • Leslie Regan Shade (University of Toronto) The Use of the Geoweb for Social Justice Activism 	

3:45 - 4pm **Coffee Break**
 Bissell Building, lobby

4 - 5:30pm **Panel Session 4**

Panel 4A	Workshop: Building Mini FM Radio Transmitters with Peter Bloom and Loreto Bravo
Date	Friday
Time	4:00 - 7pm
Room	Bissell Floor 1
<p>This workshop will run until 7pm. Please sign-up in advance at the registration desk to reserve a seat at the soldering table. Everyone is welcome to observe this hands-on skill-sharing session.</p>	

Panel 4B	Laboring Cultural Production: Circuits of Struggle in Historical and Contemporary Perspectives
Date	Friday
Time	4 - 5:30pm
Room	Bissell 538
Chair	Michelle Rodino-Colocino

- **Michelle Rodino-Colocino** (Pennsylvania State University) Making Media Work: Key Moments in the Cultural History of New Media and Management
- **Steve Macek** (North Central College) Salt of the Earth in Chicago: Anti-Communism and Censorship in the Taft-Hartley Era
- **Mary E. Triage** (University of Akron) Studying “Circuits of Struggle”: Corporate Neoliberalism and Cyberprotest in Food Activism
- **Brian Dolber** (SUNY College at Oneonta) Media and Academic Labor in the Converged Economy: Towards a New Methodology in Production Studies

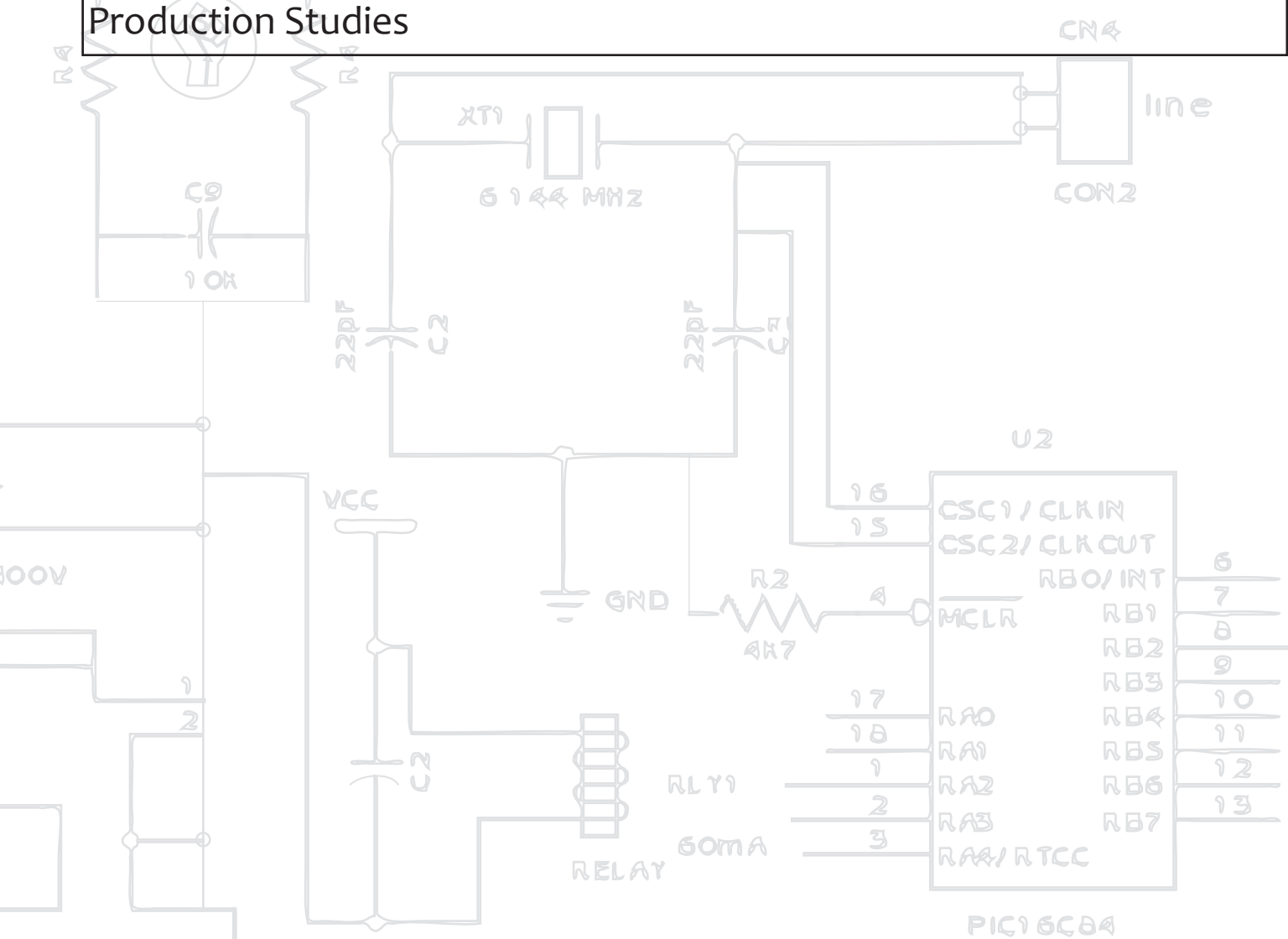

Panel 4C	Policing the Populace: Corporate Media, Social Media & the Mobilization of State Violence against Racialized Minorities
Date	Friday
Time	4 - 5:30pm
Room	Bissell 728
Chair	Aziz Douai, Julianne Condon Moderator: Miranda Brady
	<ul style="list-style-type: none"> • Derek Antoine (Carleton University) and Miranda J. Brady (Carleton University) Policing Elsipogtog: Media Discourse and Struggles to Protect First Nations Natural Resources • Chenjerai Kumanyika (Clemson University) Beyond Techno-Utopianism: The Twitter Activism of @OpFerguson • Aziz Douai (University of Ontario Institute of Technology) and Julianne Condon (University of Ontario Institute of Technology) Police Brutality in the Age of New Media: Online Audiences and the Framing of Police Use of Force against Racial Minorities in Canada • Doug Tewksbury (Niagara University) I'll Share What I See Here with the World: Social Media, Shared Empathy, and Online-Offline Interconnectedness among Ferguson Protesters

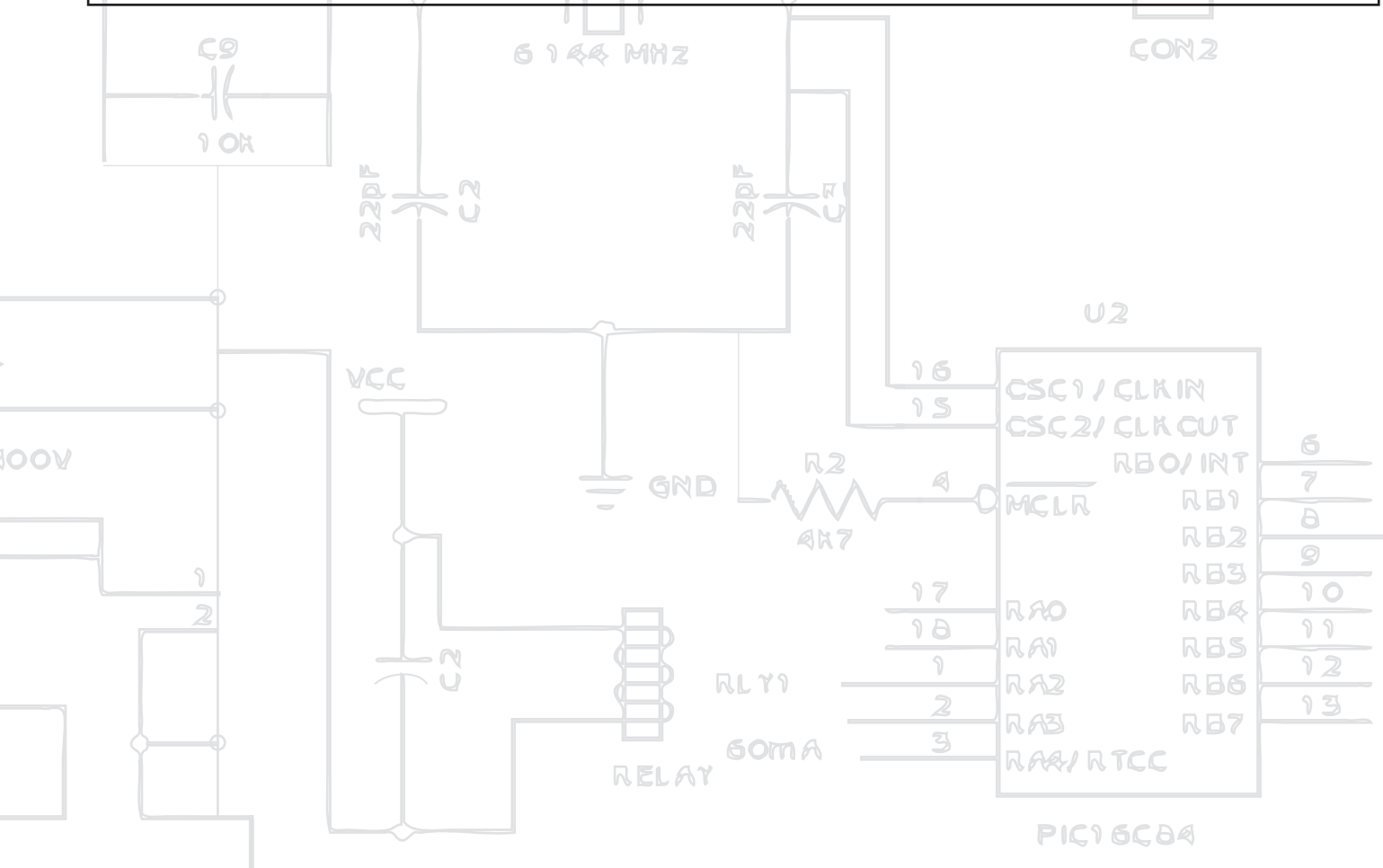

Panel 4D	Education, Pedagogy, and Critical Literacies
Date	Friday
Time	4 - 5:30pm
Room	Bissell 507
Chair	Herbert Pimlott
<ul style="list-style-type: none"> • Jennifer Simpson (University of Waterloo) The “Streamlining” of Higher Education: Resisting Neoliberal Epistemology and Imagining Justice • Herbert Pimlott (Wilfrid Laurier University) ‘The Curricula of Struggle’: Communication Tactics, Media Technologies and Campaign Strategies in and Against the Neoliberal University • Patricia Keeton (Ramapo College of New Jersey) From Wealth Inequality and DIY to Occupy and Ferguson: New Opportunities for Teaching Marxist Concepts in the Media Studies Classroom • Karen Smith (University of Toronto) and Leslie Shade (University of Toronto) Iteration, Design and Privacy Literacies 	

Panel 4E	Digital Enclosures: Manufacturing Scarcity in Networked Environments
Date	Friday
Time	4 - 5:30pm
Room	Bissell 310
Chair	Benjamin Birkinbine
<ul style="list-style-type: none"> • Greg Elmer (Ryerson University) Going Public: Accounting and Accountability in the New Media • Robert Prey (Simon Fraser University) The Struggle over Streaming: SoundCloud and the Production of ‘Abstract’ Space • Benjamin Birkinbine (University of Nevada, Reno) From the Commons to Capital: Free Software, Peer Production, and Red Hat, Inc. • John Sullivan (Muhlenberg College) Video Streaming Protocols and the Creation of Artificial Scarcity in Online Video Markets 	

Panel 4F	Theoretical Approaches to Democratic Communications
Date	Friday
Time	4 - 5:30pm
Room	Bissell 225
Chair	Susan Driver
<ul style="list-style-type: none"> • Amanda Earley (University of Leicester) The Revolution Will Not Be Tweeted: Reconsidering the Mediascape of Occupy Wall Street • Robert Danisch (University of Waterloo) Rhetorical Pragmatism, Social Democracy, and Small Group Communication • Susan Driver (York University) Affective Media Practices: Youth Articulating Difficult Feelings, Ambiguous Desires and Contradictory Identifications • James Steinhoff (Western University) “Your Body is Deathtrap”: Revolutionary Potentials in Transhumanist Conceptions of the Body • Rachel Melis (Western University) Anonymous Identities: From the Individual to the Collective 	

Panel 4G	Media Justice and Activism
Date	Friday
Time	4 - 5:30pm
Room	Bissell 224
Chair	Andy Opel
<ul style="list-style-type: none"> • Letrell Crittenden (Robert Morris University) Hands Down: Media Justice and the Decline of NABJ • Crystal China (University of Georgia) and Steven Giannino (Southern Illinois University) The Revolution will be Tweeted: Occupy the Hood Radio as Dissidence in a Mainstream Medium • Chris Robe (Florida Atlantic University) Video Guerrillas, the New Anarchism, and Lifestyle Politics • Andy Opel (Florida State University) Direct Action Pedagogy: Project Nero, Climate Change and the Florida Legislature 	

5:30 - 7pm

Book Launch

***Nothing To Lose But Our Fear: Resistance in Dangerous Times* by Fiona Jeffries** (Carleton University/SFU)

Semaphore Demo Room, Robarts Main Floor

Followed by a reception, sponsored by Between The Lines Press.

5:30 - 7pm

Dinner on your own

7:30 - 9pm

Keynote Address

Bahen Centre, 40 St. George Street, Rm 1160

Astra Taylor

Taking Back Power In the Age of Networks

The Internet is said to be a space of democratic expression and transformation, both culturally and politically. But how true is that claim? What are some of the economic, technical, and legal obstacles in place? Drawing from my recent book, *The People's Platform: Taking Back Power and Culture in the Digital Age*, and my experience as an artist and an activist, this talk will address campaigns by musicians against streaming services and debtors against creditors to reflect on the larger question of how to organize and leverage change in an age of virtual networks—be they networks of cultural distribution or financial ones.

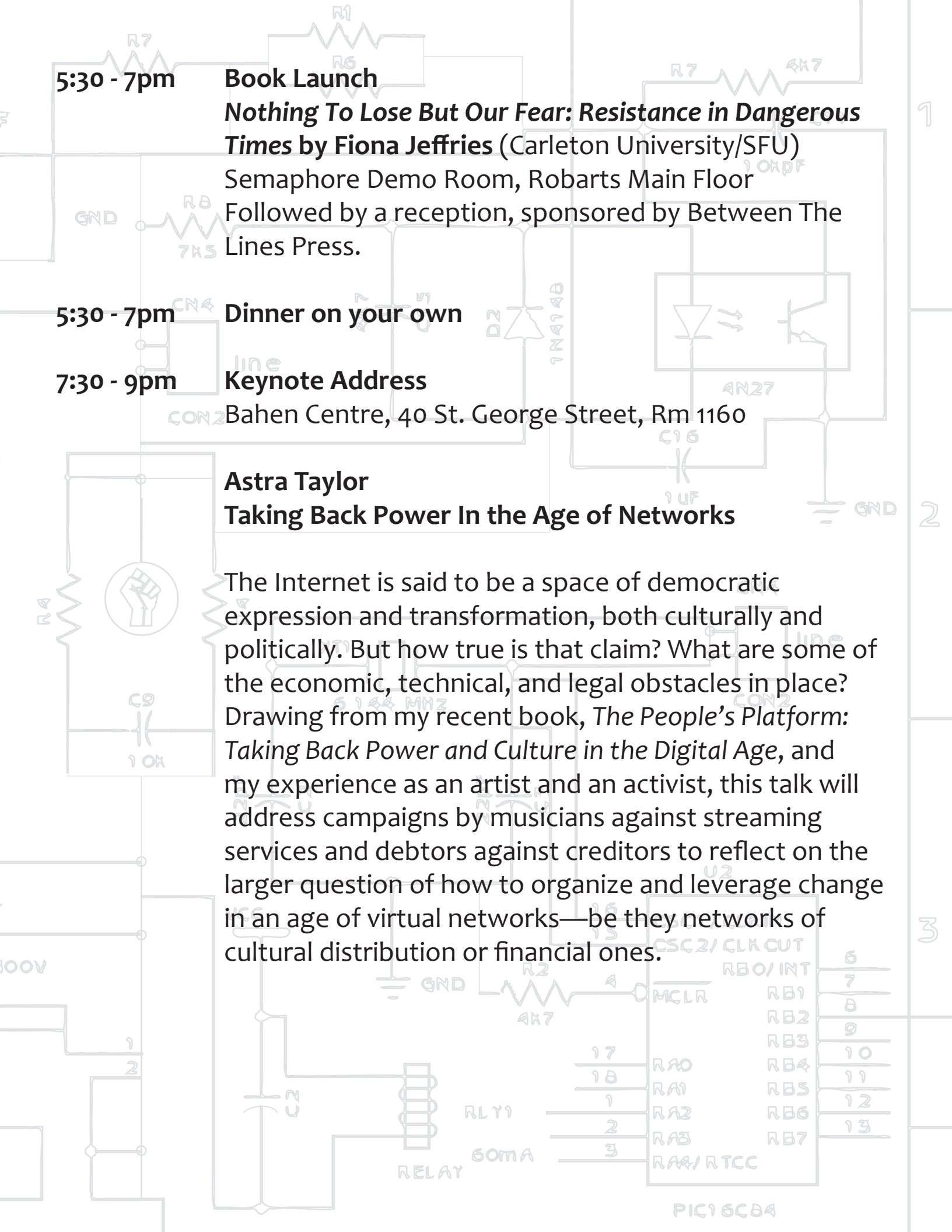

1

2

3

Saturday May 2nd

8 - 9am

Breakfast

Bahen Centre, 40 St. George Street, Rm 1160

9:30 - 10:45

Dallas Smythe Award & Lecture

Bahen Centre, 40 St. George Street, Rm 1160

Professor Robert Hackett

School of Communication, Simon Fraser University

10:45 - 11am

Coffee Break

Bissell Building, lobby

11:15 - 12:45

Panel Session 5

Panel 5A	Silencing Dissent: A Roundtable on Salaita, Academic Freedom and the Neoliberal University
Date	Saturday
Time	11:15 - 12:45pm
Room	Bissell 538
Chair	Sarah T. Roberts
	<ul style="list-style-type: none"> • Alicia Kozma (University of Illinois at Urbana-Champaign) • Rico Kleinstein Chenyek (University of Illinois at Urbana-Champaign) • Inger L. Stole (University of Illinois at Urbana-Champaign) • Molly C. Niesen (Eastern Illinois University) • Brian Dolber (SUNY Oneonta)

1

2

3

Panel 5B	Seizing Culture, Heritage, and Citizenship: Struggles Against the Appropriation of Tradition
Date	Saturday
Time	11:15 - 12:45pm
Room	Bissell 224
Chair	Henry Svec
	<ul style="list-style-type: none"> • Patrick MacInnis (University of Toronto) Appropriating City Spaces: Exploring Practice, Process and Policy in Aboriginal Street Art • Eva Athanasiu (University of Toronto) Survivance Stories: Aboriginal Networks of Resistance and New Media Art in Canada • Henry Svec (University of New Brunswick) The New Brunswick Laboratory of Imaginary Media Research + Design: A Case Study of Impossible Media Practice • Lourdes Morales (McGill University) Digital Citizen Strategies: The Present Case of the Mexican Movement for Peace

Panel 5C	Digital Labour
Date	Saturday
Time	11:15 - 12:45pm
Room	Bissell 728
Chair	Alison Harvey
	<ul style="list-style-type: none"> • Eric Lohman (Western University) Fetishizing Flexibility: The Political Economy of Telework • Alison Harvey (University of Leicester) and Stephanie Fisher (York University) Games of Resistance: Women's Work, Community, and the Democratization of Game Design • Harrison Smith (University of Toronto) Conventions of Sharing: Situating Labour and Exploitation Within the Sharing Economy • Florian Schmidt (Royal College of Art) The Design of Creative Crowdwork From Tools for Empowerment to Platform Capitalism

Panel 5D	Mediated Subjectivity and Workers' Struggles
Date	Saturday
Time	11:15 - 12:45pm
Room	Bissell 205
Chair	Jack Z. Bratich
	<ul style="list-style-type: none"> • Gary Kinsman (Laurentian University) Of Newsletters and Pamphlets: Autonomist Communication and Organizing in 1970s 'Canada.' • Dorothy Kidd (University of San Francisco) New Enclosures and New Commons: Struggles Over Neo-Extractionism • Jack Z. Bratich (Rutgers University) Social Bodies in Movement, Social Bodies at Rest: A Compositionist Media Studies Approach to Contemporary Struggles • Marco Deseriis (Northeastern University) The Power of Refusal and the Production of Subjectivity Without a Subject

Panel 5E	Communications Policy and the Public Interest
Date	Saturday
Time	11:15 - 12:45pm
Room	Bissell 310
Chair	Michael Lithgow
	<ul style="list-style-type: none"> • John Anderson (Brooklyn College) Workers Independent News v. FCC: Busted by the News Police • Michael Lithgow (McGill University) Un/reasonable Power: An Aesthetic Discourse Analysis of Public Participation In Canadian Broadcasting Policy • Ian Kivelin Davis (Augustana College) International News Flow and the Distribution Question: China, Falun Dafa and Pluralism in Canadian Media Policy • Ilya Kiriya (National Research University Higher School of Economics) How International Sanctions Contributed to Additional Monopolization of Russian Media

Panel 5F	Labour Struggles in Cultural Industries
Date	Saturday
Time	11:15 - 12:45pm
Room	Bissell 507
Chair	Matt Stahl
	<ul style="list-style-type: none"> • Christine Quail (McMaster University) Dance For Your Life: Dance, Labour, Reality Television • Matt Stahl (Western University) Royalties Delayed are Royalties Denied: Aging R&B Performers' Late-Career Struggles for Economic Justice • Errol Salamon (McGill University) Alternative Journalism as Direct Action: Locked Out and Striking Newswriters Produce Média Matin Québec

12:45 - 1:45 Lunch and UDC General Membership Meeting
 Howard Ferguson Hall, 75 St. George Street

2 - 3:30pm Panel Session 6

Panel 6A	New Strategies in Media Worker Organizing
Date	Saturday
Time	2 - 3:30pm
Room	Bissell 224
Chair	Katherine Lapointe
	<ul style="list-style-type: none"> • Katherine Lapointe (Communication Workers of America-Canada) • Datejie Green (Canadian Media Guild) • Karen Wirsig (Canadian Media Guild)

Panel 6B	A Military-Industrial-Communications-Complex in Canada? Roundtable and Discussion
Date	Saturday
Time	2 - 3:30pm
Room	Bissell 225
Chair	Patricia Mazepa
<p>Organized into three overlapping groups, the roundtable identifies the institutional and symbolic links between the Canadian military, ICT and media firms, discusses comparisons in other nation-states, and highlights emerging challenges to the MICC.</p> <ul style="list-style-type: none"> • Patricia Mazepa (York University) • Kirsten Kozolanka (Carleton University) • Tanner Mirrlees (University of Ontario Institute of Technology) • Neil Balan (Wilfrid Laurier University) 	

Panel 6C	We Don't Need No (Public) Education: Political Struggle Over the Neoliberalization of Public Education
Date	Saturday
Time	2 - 3:30pm
Room	Bissell 205
Chair	Janice Peck
<ul style="list-style-type: none"> • Janice A. Newson (York University) Public Education in a Neo-liberal Stew • Alison Hearn (Western University) Public Institutions and Privatized Measures: Toward a Political Economy of Research Metrics • Steve Macek (North Central College) "Putting Adults Ahead of Children": Local News Media's Framing of the Chicago Teacher's Union, 2003-2013 • Janice Peck (University of Colorado at Boulder) "Placing Education Above Politics": The Ideological Work of the <i>New York Times</i> in the Rise of the "Education Reform Movement" 	

Panel 6D	Struggles over Digital Technologies
Date	Saturday
Time	2 - 3:30pm
Room	Bissell 728
Chair	Sherry Yu
	<ul style="list-style-type: none"> • Sherry Yu (Temple University) Ethnic Media and New Media Technologies • Elise Thorburn (University of Western Ontario) Technologies of the Carceral and Securitized Social Reproduction: Prison Technology in Canada • David Jackson (Western University) Militant Sound Investigation: Tactical Field Recording in the War Against the Poor • Andrew Mestrinaro (University of Ontario Institute of Technology) The Cryptocommunity of Silk Road as Heterotopia

Panel 6E	Constructing Political Reality: Media Coverage and Framing
Date	Saturday
Time	2 - 3:30pm
Room	Bissell 538
Chair	Dan Tamul
	<ul style="list-style-type: none"> • Dan Tamul (Indiana University-Purdue University) and Nadia Martinez-Carrillo (Indiana University-Purdue University) Big Media, Big Databases, Big Problems: A Critical Examination of Database Driven Samples in News Framing Analysis • Richelle Crotty (Florida State University) The All-Female Jury: A Feminist Political Economic Analysis of the Zimmerman Trial Jurors • Martin Marinos (University of Pittsburgh) Media Transformation and the Populist Far-Right in Southeastern Europe: Bulgaria's "Ataka" Party and Post-Socialist Neoliberalism

Panel 6F	Struggles in Global Media
Date	Saturday
Time	2 - 3:30pm
Room	Bissell 507
Chair	Lee Artz
<ul style="list-style-type: none"> • Lee Artz (Purdue University Calumet) Power and Communication: Working Class Leadership in Public Media Access • Guy Hoskins (York University) Programming Power: Internet Policymaking at the Network's Edge and the Case of Brazil's Marco Civil • Samuel Barros (CEADD, UFBA/MIT) The Internet as Platform for the Inclusion of Citizens in the Democratic Decision Making Process: A Report From Brazil • Awais Saleem (Florida State University) and Stephen McDowell (Florida State University) The Political Economy of News Television in Pakistan 	

3:30 - 3:45pm Coffee Break
 Bissell Building, lobby

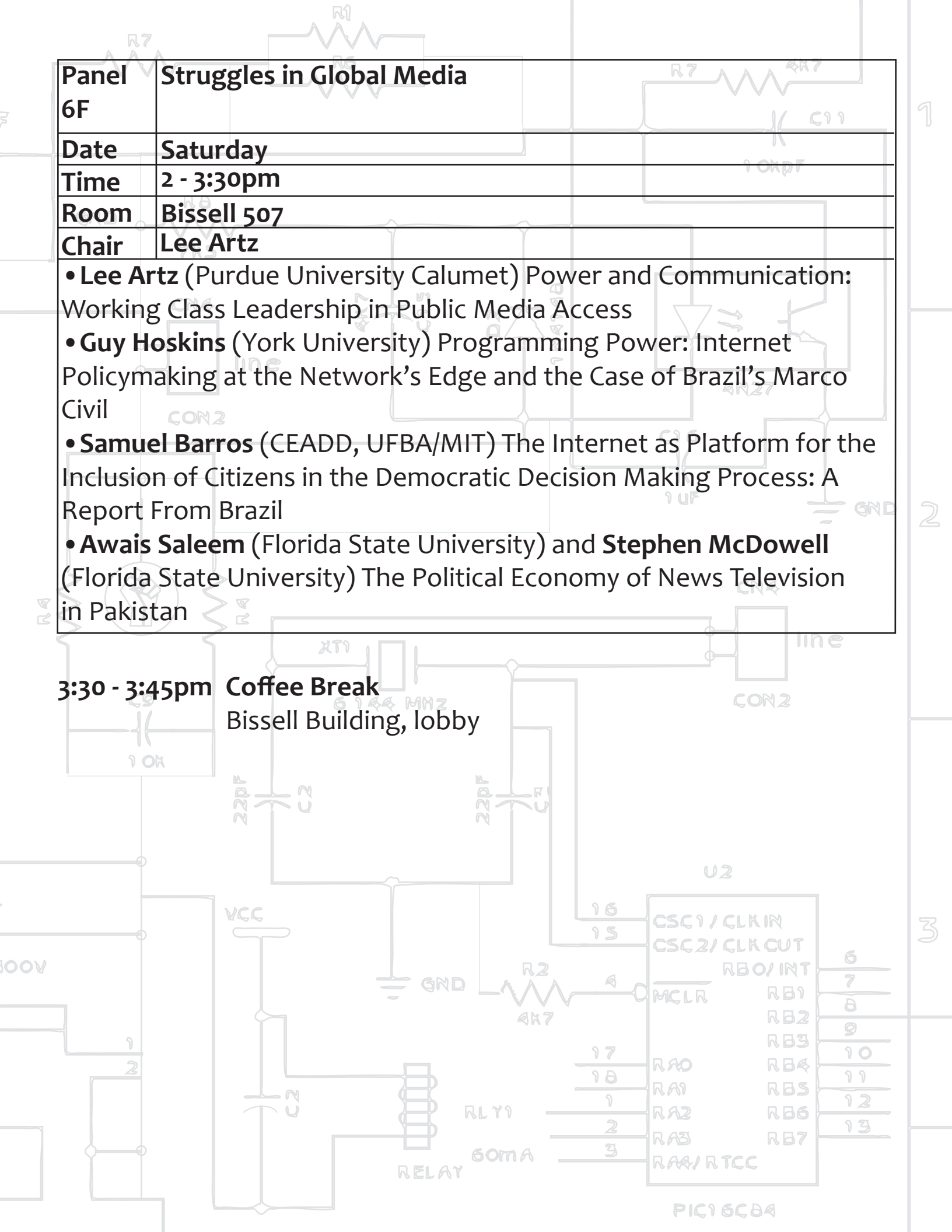

3:45 - 5:15

Panel Session 7

Panel 7A	Community Media Policy in the Digital Environment
Date	Saturday
Time	3:45 - 5:15pm
Room	Bissell 507
Chair	Catherine Edwards/CACTUS
<ul style="list-style-type: none">• Catherine Edwards (Canadian Association of Community Television Users and Stations), Kirsten Kozolanka (Carlton University), David Murphy and Darryl Richardson <p>This workshop will 1) assess the current policy background for community media in Canada compared to that in other countries; 2) share a plan to hold a multi-platform community media conference in 2015 to inform upcoming CRTC policy deliberations; and 3) identify the most pressing policy gaps and issues for community media in Canada, which will feed into the upcoming conference (ComMedia 2015) and accompanying policy development process.</p>	

Panel 7B	The Food System as a Circuit of Struggle and Hope
Date	Saturday
Time	3:45 - 5:15pm
Room	Bissell 224
Chair	Mary Triece
<ul style="list-style-type: none">• Christina Ceisel (Hamilton College) Will Blog for (and about) Work: Gendered Iterations of Food Labor and Social Media• Mary Triece (University of Akron) Food and Race in the Organizing of Black Urban Farmers	

Panel 7C	Beyond #Activism: FemTechNet Collaborations in Digital Pedagogy and Feminist Technology
Date	Saturday
Time	3:45 - 5:15pm
Room	Bissell 728
Chair	T.L. Cowan
<ul style="list-style-type: none"> • Melissa Meade (Colby-Sawyer College) and Cricket Keating (The Ohio State University) From 'Do it Yourself' to 'Doing With Others': #feminism Across FemTechNet • Joan Donovan (University of California San Diego) What is a Broadcast? Activist Archives and Transmedia Storytelling • KJ Surkan (MIT) Hacking the Global Map: Connected Cartography in the Feminist Classroom • Sky Croeser (Curtin University) Feminist Critiques of Digital Liberties Activism: Pathways to Transformative Change 	

Panel 7D	Anonymity, Identity, and Journalism in the Snowden Era
Date	Saturday
Time	3:45 - 5:15pm
Room	Bissell 538
Chair	Robert Bodle
<ul style="list-style-type: none"> • Brian Creech (Temple University) Our Man in the Field: Digital Tools, Citizen Reporting, and the Displacement of Journalistic Risk • Christian Oquendo Sanchez (York University) Updating Digital Divides, State Control, Public Debates and Journalistic Practice in the Context of Socialism of the 21st Century: The Case of Ecuador • James F. Hamilton (University of Georgia) Show Your Faces: Notoriety and Online Security • Robert Bodle (Mount St. Joseph University) Online Anonymity, Whistleblowing, and Journalistic Standards 	

Panel 7E	Hacking Neoliberalism: Short Circuiting Control
Date	Saturday
Time	3:45 - 5:15pm
Room	Bissell 205
Chair	A.T. Kingsmith
<ul style="list-style-type: none"> • Robert E. Latham (York University) Neoliberalism and the Spatialities of Struggle: Possibilities for Re-Collective Passage • William S. Jaques (York University) The Internets is SRS BZNS: Politicization, Monetization and Control in the Cybersphere • Julian von Barga (York University) Prosumers and Private Public Spheres: The Socio-Digital Structural Limitations of Internet.org • Thomas N. Cooke (York University) Privacy Stories (Ret)old: Corporate Programming, Neoliberalism and Hacktivism at the Stanford University • A.T. Kingsmith (York University) The Hacker Aesthetic: Re-imagining Resistance and Ideology with/in Neoliberal Spaces 	

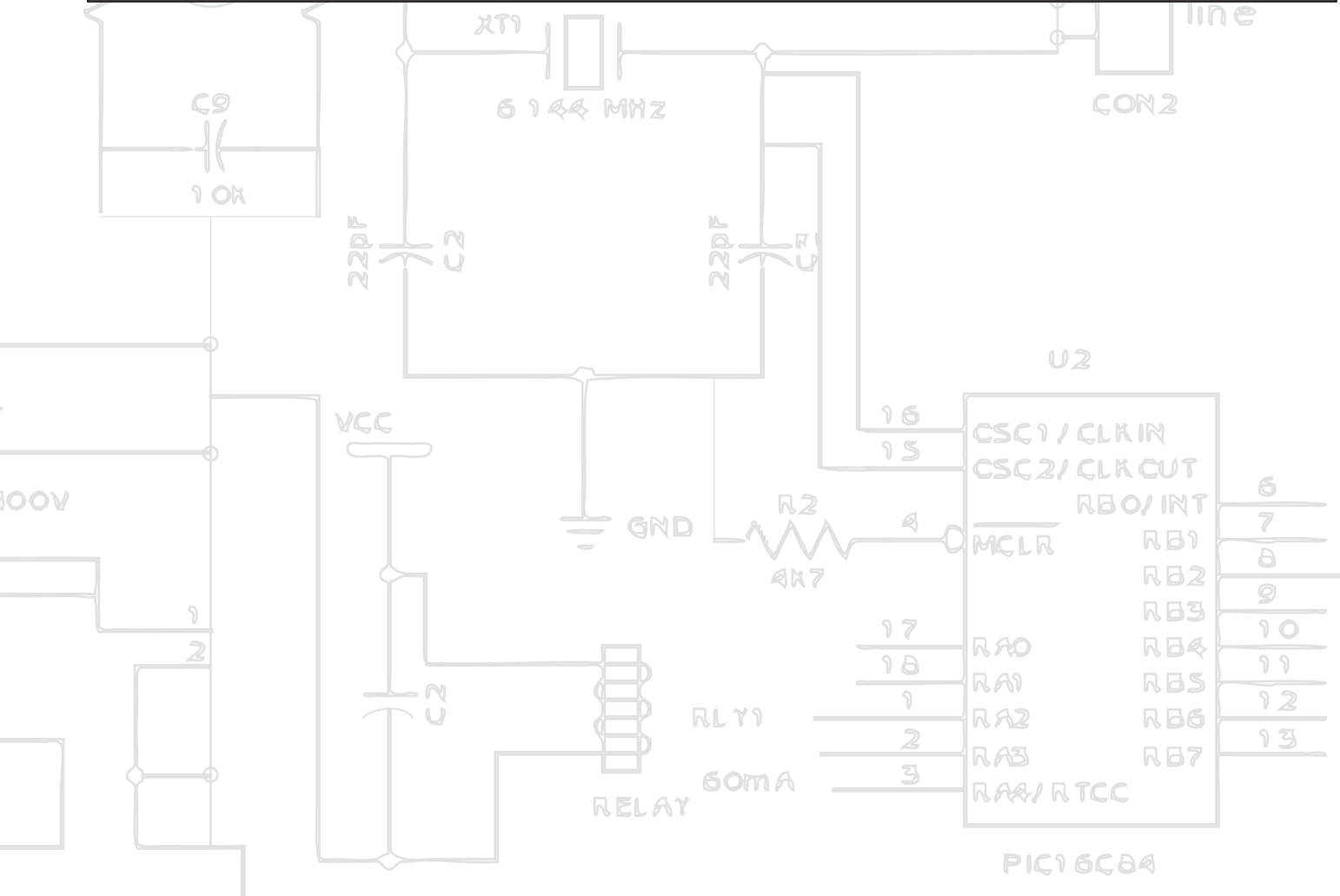

Panel 7F	Exercises for the Critical Classroom
Date	Saturday
Time	3:45 - 5:15pm
Room	Bissell 310
Chair	Randy Nichols
	<ul style="list-style-type: none"> • Marc Ouellette (Reconstruction: Studies in Contemporary Culture) It's all out and you know: Interpellation, The Self and Others • Joe Tompkins (Allegheny College) Against Individualistic Thinking: Teaching Capitalism and Racism as Social Systems • Randy Nichols (Bentley University) Rendering the Invisible Hand: Making Sense of Concentration and Competition in the Classroom • Chris Demaske (University of Washington, Tacoma) Who Gets to Speak: Unlocking the Mysteries of First Amendment Application • James Wittebols (Union for Democratic Communications) A Course to Help Students Become More Critical Researchers: Information Searching and Analysis

6pm

Circuits of Struggle Plenary (doors & refreshments 5:15)
Burwash Dining Hall, 89 Charles St. W.

Ursula Huws (University of Hertfordshire)

Harry Cleaver (University of Texas at Austin)

Alison Hearn (University of Western Ontario)

Nick Dyer-Witheyford (University of Western Ontario)

7:30pm

Dinner and dance

Burwash Dining Hall, 89 Charles St. W.

DJ CHRONOLOGIC, a dance party through the ages, a survey of eclectic dance music of the last hundred years, a.k.a. the absolute best dance tracks from every era... from the 1890s to 2015, played in chronological order.

Sunday May 3rd

8:30 - 9am Breakfast

Howard Ferguson Hall, 75 St. George Street

9 - 10:30am UDC Business Meeting (all welcome)

Howard Ferguson Hall, 75 St. George Street

10:30 - 11:45 Panel Session 8

Panel 8A	The Financialization of Documentary, Documenting Financialization: Activist Cultural Production in an Age of Speculative Capital
Date	Sunday
Time	10:30 - 11:45am
Room	Bissell 538
	• Max Haiven (NSCAD) and Ezra Winton (NSCAD)

Panel 8B	Social Reproduction and the Emerging Institutions of the Common
Date	Sunday
Time	10:30 - 11:45am
Room	Bissell 728
Chair	Marco Deseriis
	• Elise Thorburn (University of Western Ontario) Communication Technologies and Social Reproduction: Securitized and Autonomous
	• Fiona Jeffries (Carleton University/SFU) and Pablo Mendez (Carleton University) Turning the Home Inside Out: Commoning Care in the Political Encampment
	• Enda Brophy (Simon Fraser University) Cultural Workers Occupy

Panel 8C	Rules and Resources: Tapping the Potential of Technology
Date	Sunday
Time	10:30 - 11:45am
Room	Bissell 507
Chair	Gregory Taylor
	<ul style="list-style-type: none"> • Gregory Taylor (Ryerson University) and Catherine Middleton (Ryerson University) Spectrum Allocation: Best Practices for a Public Resource • Frederick Emrich (KIMEP University) Toronto Public Library and “Maker Culture” • Ishanie Perera (University of Toronto) and Curtis McCord (University of Toronto) Canadian Internet Infrastructure: Cloudy with a Chance of Sublimation • Evan Light (Concordia University) Appropriate Telecom: Hacking Big Telecom From Within

Panel 8D	(Re)wiring Struggle and Transformation in Journalism Research and Education
Date	Sunday
Time	10:30 - 11:45am
Room	Bissell 225
Chair	Andrea Hunter
	<ul style="list-style-type: none"> • Andrea Hunter (Concordia) & Jessica Sanchez (Concordia) (Re)Fund: Opportunities and Ethical Issues in Journalism and Crowdfunding • David Secko (Concordia) (Re)Modeling: An Experiment in Providing Students with Alternative Frameworks for Science Journalism Production • Stanton Paddock (Concordia) (Re)work: Who do we Work for? Accreditation and the Historical Shift in Journalism Education’s Purpose • Isabel Macdonald (Concordia) Comics Journalism: Illustrating a Critical Journalism/Research Practice

Panel 8E	Political Economies of Popular Culture
Date	Sunday
Time	10:30 - 11:45am
Room	Bissell 310
Chair	Aaron Heresco
	<ul style="list-style-type: none"> • Peter Scheckner (Ramapo College) <i>Apocalyptic, and Science Fiction Films: How Hollywood and Television Imagines Social Inequality, People’s Power, and the State</i> • Joe Tompkins (Allegheny College) <i>The Makings of a “Revolutionary” Franchise: Promotional Cynicism and <i>The Hunger Games</i></i> • Azmat Rasul (Florida State University) and Jennifer Proffitt (Florida State University) <i>A Passage to India: Indian Film Market and the Political Economy of Disney’s Transnational Operations</i> • Aaron Heresco (California Lutheran University) <i>Audience Commodity Revisited: Affiliate Fees and the Changing Product of Television</i>

11:45 - 12pm **Coffee Break**
 Bissell Building, lobby

12 - 1:15pm **Panel session 9**

Panel 9A	Feminist Media Making: Sharing What We Know, Searching for What We Need, Archiving What We Have
Date	Sunday
Time	12 - 1:15pm
Room	Bissell 224
	<ul style="list-style-type: none"> • Elise Thorburn (University of Western Ontario) • Sheila Sampath (<i>Shameless</i> magazine/<i>The Public</i>)

Panel 9B	Network Neutrality: Reflection and Critique Towards a New Circuit of Struggle
Date	Sunday
Time	12 - 1:15pm
Room	Bissell 538
Chair	Brian Dolber
<ul style="list-style-type: none"> • Brian Dolber (SUNY College at Oneonta) Race, Informationism and the Network Neutrality Debate: Towards a Critical Race Theory of Technology Policy History • John Anderson (CUNY-Brooklyn College) Astroturf Blowback • Russell Newman (Emerson College) Network Neutrality's 2014 Boost: Beyond Open and Closed, the Consequences and Labors of a Neoliberal Debate 	

Panel 9C	Social Movements and Digital Technologies
Date	Sunday
Time	12 - 1:15pm
Room	Bissell 310
Chair	Elisabetta Ferrari
<ul style="list-style-type: none"> • Stéphane Couture (McGill University) and Sophie Toupin (McGill University) Digital Infrastructures and/or Social Movements: Contradictions and Convergences • Elisabetta Ferrari (University of Pennsylvania) Social Media for the 99%? Rethinking Alternative Media and Social Movements' Identity in the Corporate Web 2.0. • Anne-Marie Romanko (University of Windsor) Pepper Spray, Photoshop, and Protest: The Meme as a Tool for Socio-Political Protest 	

Panel 9D	News Media and the Promise of Participatory Politics
Date	Sunday
Time	12 - 1:15pm
Room	Bissell 507
Chair	Jennifer Proffitt
<ul style="list-style-type: none"> • Rich Templin (Florida AFL-CIO) and Jennifer Proffitt (Florida State University) <i>The Devil's in the Details: Media Coverage of Florida's Ongoing Pension Battle</i> • Jessica Sanchez (Concordia University) <i>Madame Premier, How Does the Press See You?: Sexism and Gender Differences in Newspaper Coverage of Canadian Female Premiers</i> • Shea Smock (Independent Scholar) <i>Replacing the Horse Race & Suppressing Protest: Findings from a Political Economic Analysis of Super PAC News Coverage</i> • Nadia Martínez-Carrillo (Indiana University-Purdue University) and Dan Tamul (Indiana University-Purdue University) <i>Shale We be Friends?: Analyzing International Criticism of a Repressive Regime in the Context of Neoliberal Energy Politics</i> 	

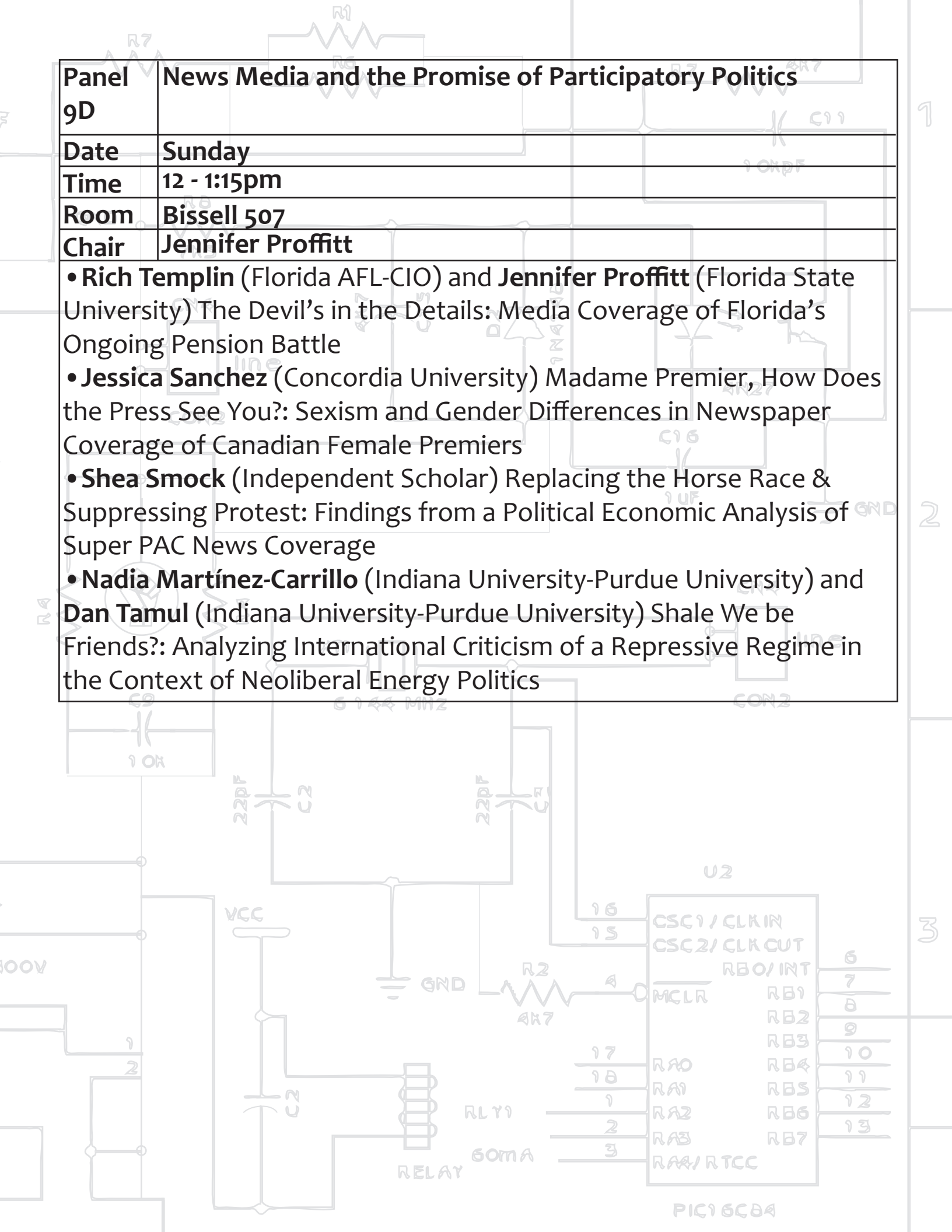

Panel 9E	Media and Empire in the 21st Century
Date	Sunday
Time	12 - 1:15pm
Room	Bissell 728
Chair	Paula Chakravartty, Discussant: Yuezhi Zhao

- **Paula Chakravartty** (New York University) *The Infrastructures of the Empire of Liberty*
- **Adel Iskandar** (Simon Fraser University) *Imperial Transculturalism: Neoliberalism Meets Mainstreamed Alterity*
- **Deepa Kumar** (Rutgers University) and **Arun Kundnani** (New York University) *Security as Psychological Wage: Race, Surveillance, and Empire*
- **Wazmah Osman** (Simon Fraser University) *Malala and the Other Activists You Haven't Heard of—The Workings of Gender and Empire*

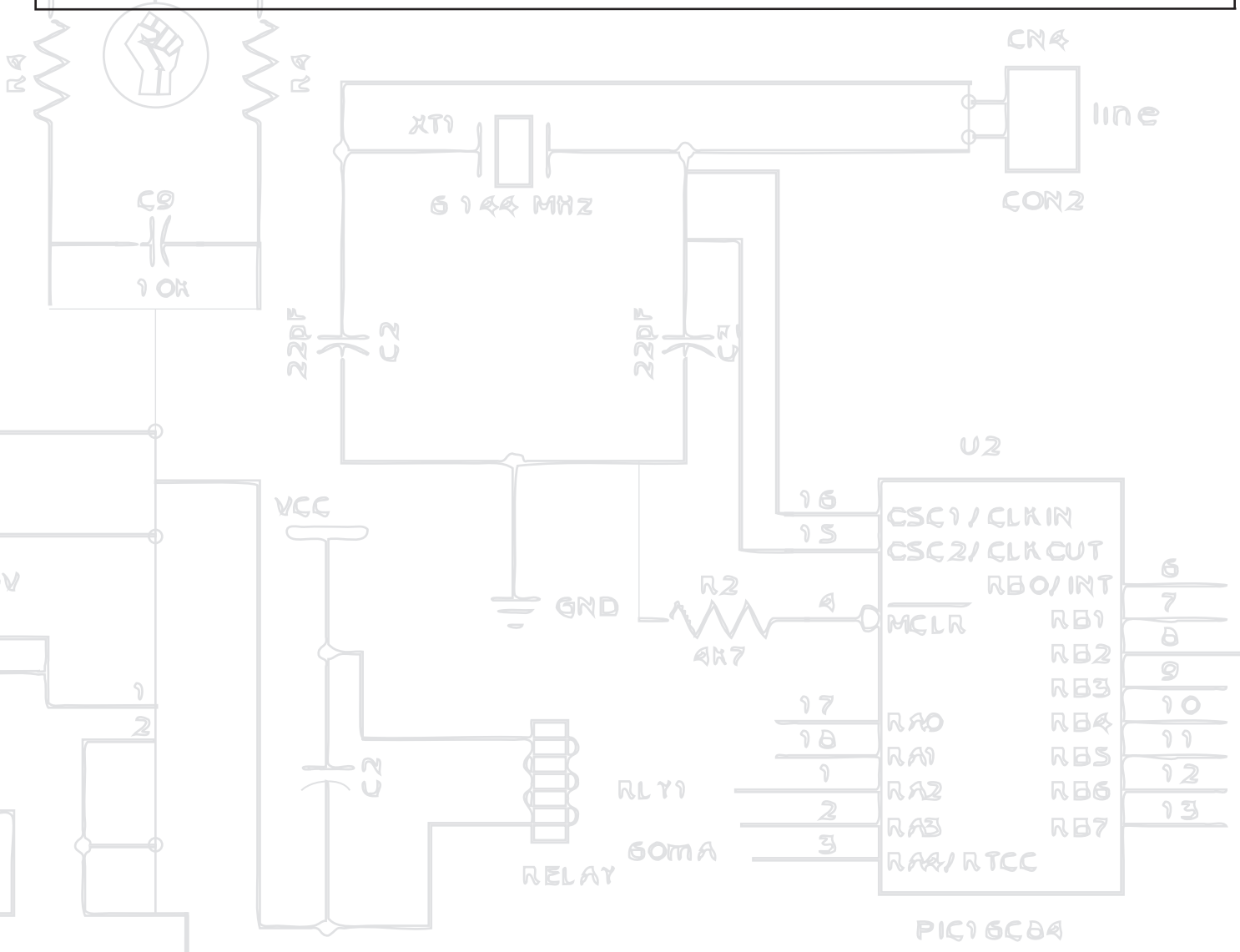

1:30 - 2:45pm **Closing Lunch and Plenary**

Howard Ferguson Hall, 75 St. George Street

Ruptures and Critical Junctures: Moments of Media Activism in Historical and Global Contexts

Anita Say Chan (University of Illinois, Urbana-Champaign) **Networking Peripheries: Technological Futures, Informatic Contests and the Myth of Digital Universalism**

Victor Pickard (University of Pennsylvania) **The Postwar Triumph of Corporate Libertarianism and the Future of Media Reform**

Christina Dunbar-Hester (Rutgers University) **Old Media, New Politics? Low-Power FM Radio Activism in the Age of “The Digital”**

Todd Wolfson (Rutgers University) **Digital Rebellion: The Cultural Logic of Contemporary Social Movements**

Discussant: Deepa Kumar (Rutgers University)

Local organizing committee:

Brett Caraway
Nicole Cohen
Gretchen King

UDC Steering Committee:

John Anderson
Robert Carley
Nicole Cohen
Matthew Crain
Chris Demaske
Brian Dolber
Randy Nichols
Molly Niesen
Sarah T. Roberts
Michelle Rodino-Colocino
Inger L. Stole
John Sullivan
Doug Tewksbury

Special thanks:

Rob Carley
Carolyn Dineen
Randy Nichols
Leslie Shade
Doug Tewskbury
Ben Walsh
Seamus Ross
Anthony Wensley
Christopher Young
Glen Menzies
Lorie King of Union Pride
Social Science and Humanities Research Council of Canada
The many people who reviewed abstracts

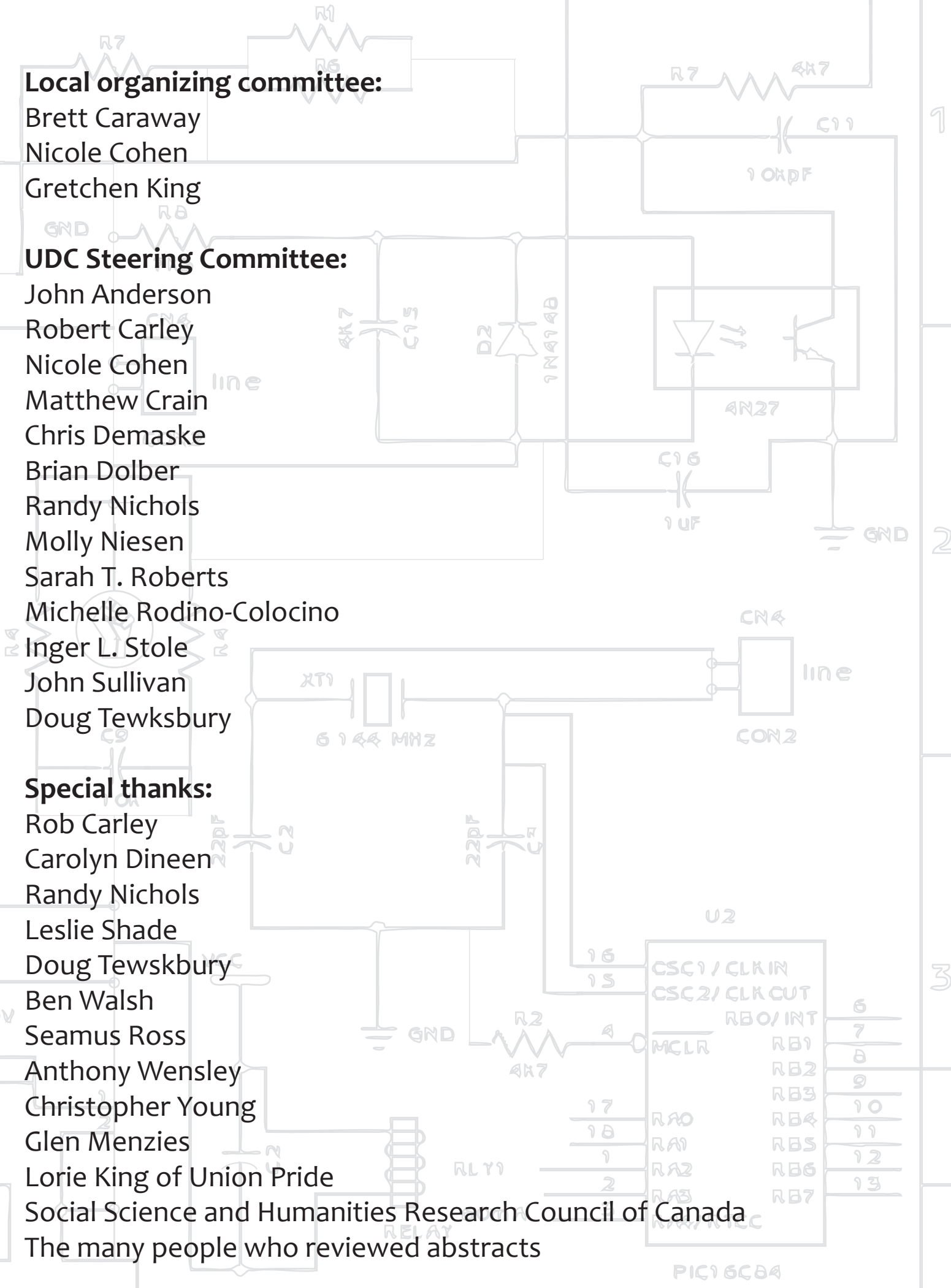

Sponsors:



Institute of Communication, Culture, Information & Technology
University of Toronto Mississauga



UNIVERSITY OF TORONTO
FACULTY OF INFORMATION



Social Sciences and Humanities
Research Council of Canada

Conseil de recherches en
sciences humaines du Canada

Canada

rabble.ca



BTL

Circuits of Struggle logo and design:

Brett Caraway

www.democraticcommunications.org

Twitter: @UDCtweets

udc2015.wordpress.com

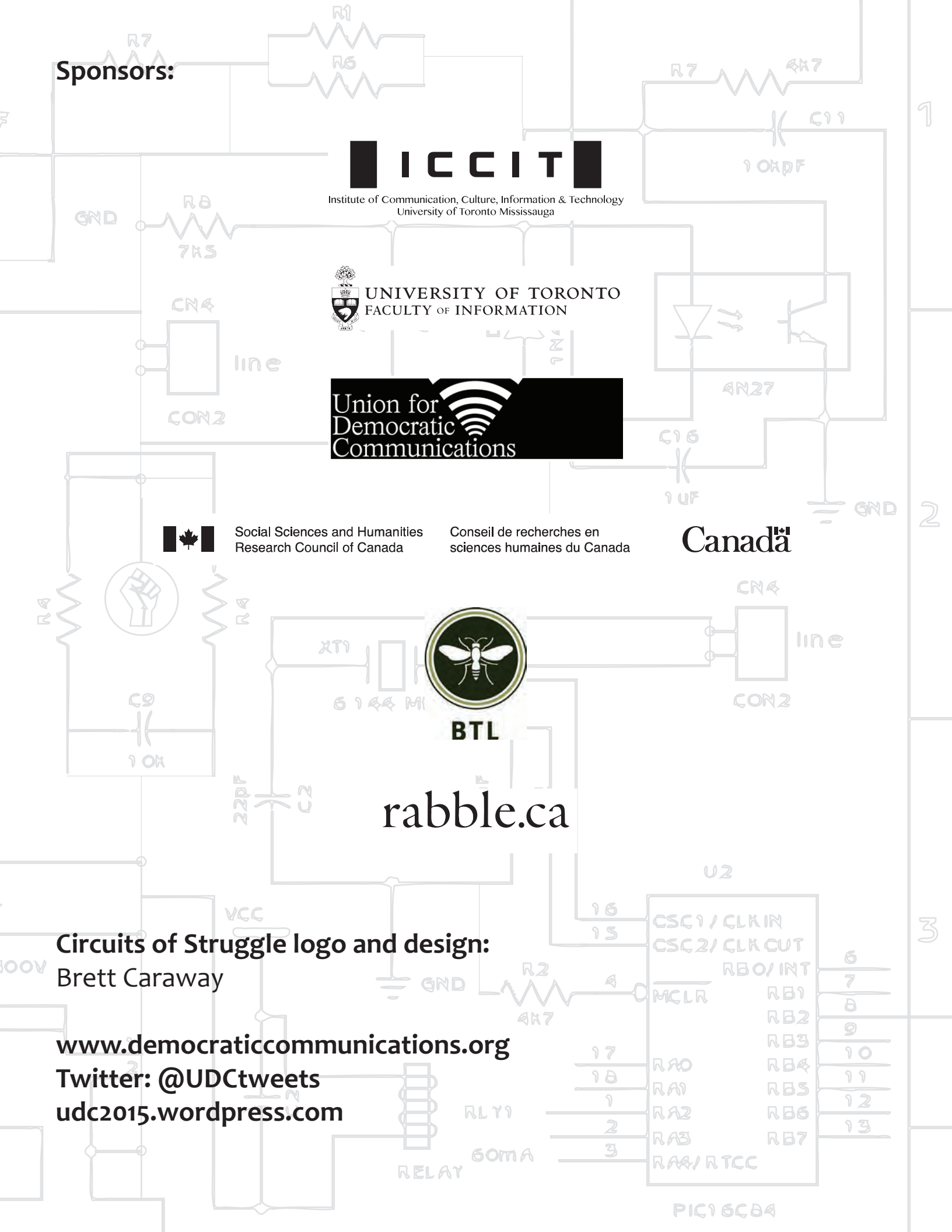

1

2

3

Notes:

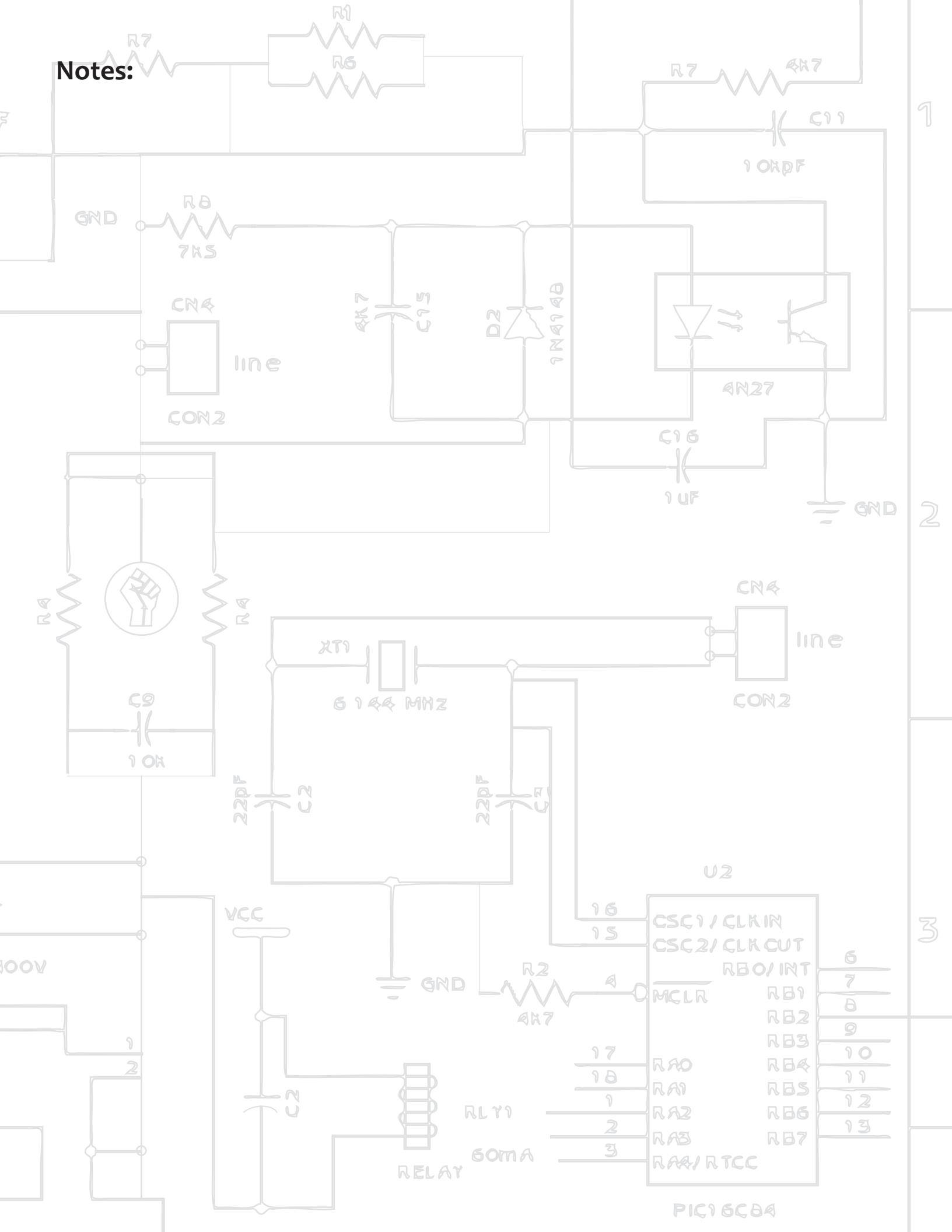

1

2

3